

Visualise This

MEETING

Visualise This



MALAYSIA  
Bristol Technologies Sdn Bhd  
Lot 5178 Balakong Jaya Light Industri  
43300 Seri Kembangan, Selangor, Malaysia.  
Tel: +603 8962 3233  
Fax: +603 8962 6322  
Email : export@bristol.com.my  
Web: www.bristol.com.my  
 [www.facebook.com/bristolfurniture](http://www.facebook.com/bristolfurniture)



Meeting spaces is where people meet to discuss a particular topic.



*Formal*



*Informal*

Vertigo can be adjusted easily to any height (650mm-1200mm) from a sitting to a standing position. This allows a more informal style of meeting, thus to a healthier and naturally more productive workplace.

## What is...

### Meeting room

- Function- Less formal discussion
- Space- Small to medium
- Capacity- 2 to 10 pax



### Boardroom

- Function- Formal and important decision making
- Space- Medium to large
- Capacity- 2 to 12 pax
- Equipment- AV and individual power supply



### Conference room

- Function- Formal and important decision making
- Space- Medium to large
- Capacity- more than 12 pax
- Equipment- AV, internet and individual power supply



What about **shapes**?

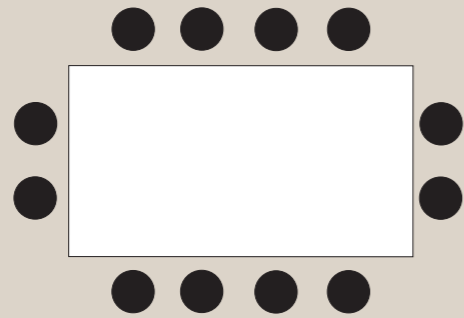

Rectangular

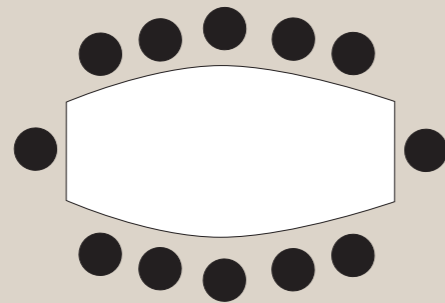

Boat

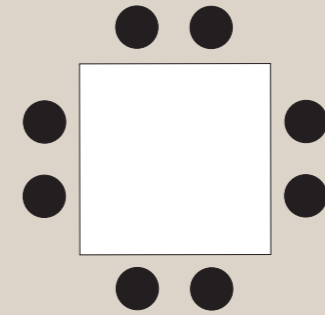

Square

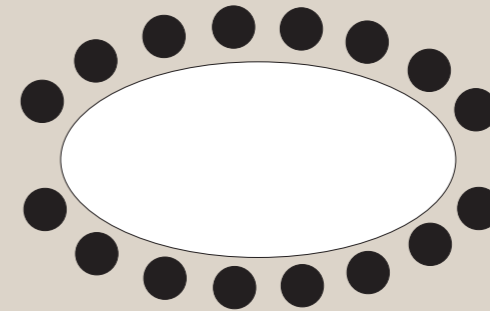

Oval

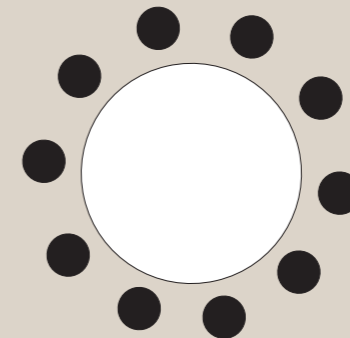

Round



Artiv Curve Leg  
 Worktop in Formica 5483UN Mocca Firwood  
 Base in white sand finish  
 Como Talk chairs in white mesh

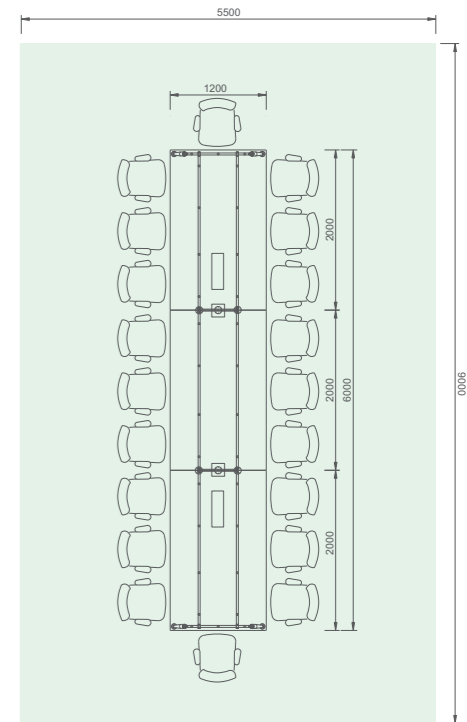

## Rectangular

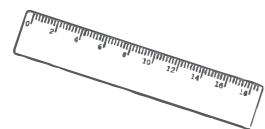

- Classic shape.
- Small to bigger meeting space.
- End of table allows chairing the meeting.

# Round



- Perfect for small to medium-sized room,
- Typical worksurface size of 900mm to 1500mm.
- Creates equal alliance.
- Appropriate for intense collaborative discussion.

*Fadz*  
 Worktop in MFC Black.  
 Base in chrome and black finish.  
 Team cantilever chairs in fabric.

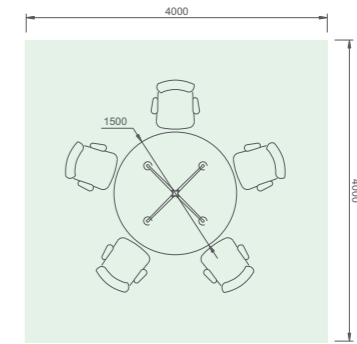

*Sunflower*  
 Worktop in MFC Black  
 Base in silver smooth finish  
 Kleiber chairs in fabric



# Square



- Good for small number of attendees.
- Maximum seating of 8 pax on worktop of 1800mm.
- Good for project discussion that requires table space for large papers, etc.

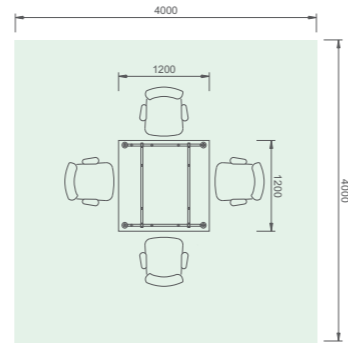

*Artiv Straight Leg*  
 Worktop in MFC Dark Walnut  
 Base in white sand finish  
 Como Talk chairs in black mesh



*O Series*  
 Worktop in HPL 9578UN Mali Wenge  
 Base in silver metallic finish.  
 Como Talk chairs in black mesh.

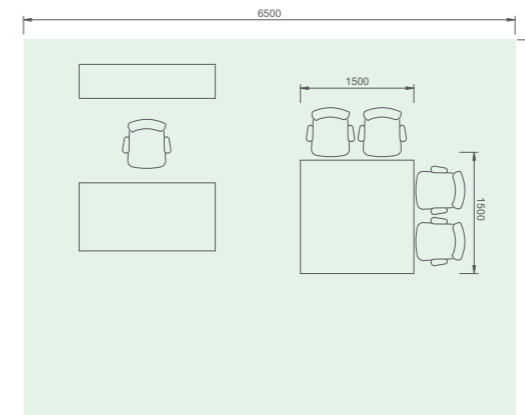

# Oval

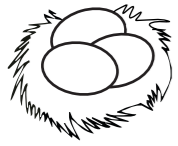

- Combines modern styling with classic sensibility.
- Excellent choice for narrow or small room, with the need to seat more people.
- Promote both equality and hierarchy.

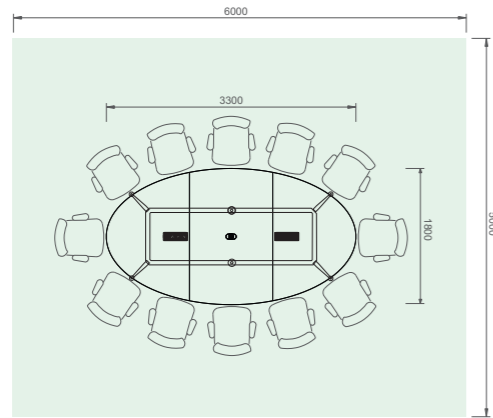

Como System  
Worktop in MFC MaliWenge  
Base in chrome finish  
Como Talk chairs in white mesh

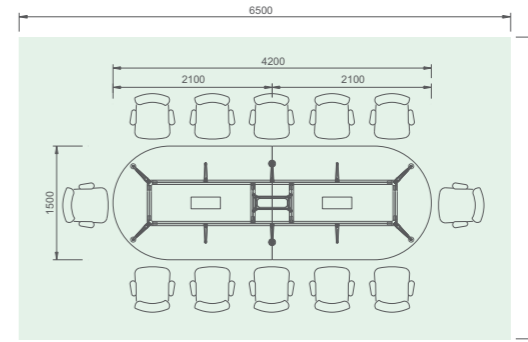

Como System  
Worktop in MFC Aborn Natur.  
Base in chrome finish.  
Soul chairs in black mesh.





# Boat



- Distinctive style that draws attention.
- Typically used in boardroom / conference room where style is exhibited.





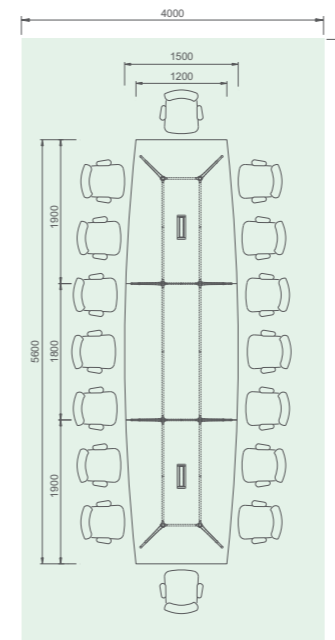
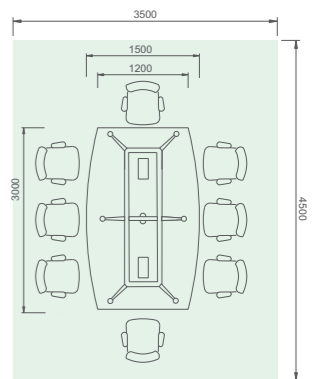

Como  
Worktop in MFC Black.  
Base in chrome finish.  
Como Pad chairs in black leather.

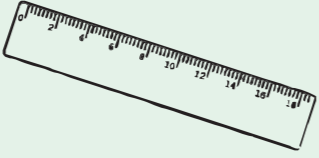

Fadz  
Worktop in Veneer China Ash Classis.  
Base in chrome finish.  
Como Talk chairs in white mesh.

# shape comparison

	 <b>Rectangular</b>	 <b>Round</b>	 <b>Square</b>	 <b>Oval</b>	 <b>Boat</b>
Space requirement	Medium to large size room	Small to medium size room	Small to medium size room	Small to large size room	Medium to large size room
Appearance	Distinctive and classic shape	Equal and balance in shape	Equal and balance in shape	Combine modern styling with classic sensibility	Distinctive style
Benefit	Creates boundaries of power differential. End of table allows chairing of meeting.	Promote equality. Good use of space. Promote better interaction.	Good for project discussion that requires table space for bigger papers and etc.	Similar to rectangular but creates a feeling of equality comfort for everyone with its rounded corners.	Shape that draws attention. Typically used in boardroom and conference room.

What about larger groups of people?

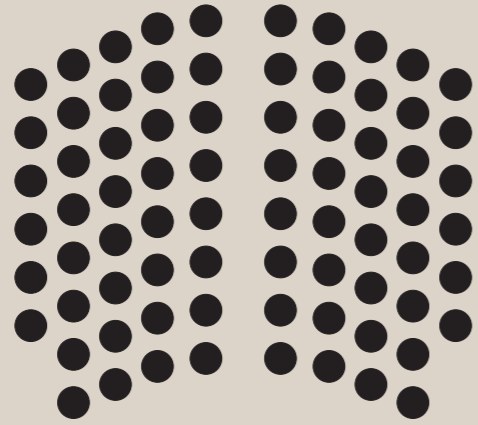

Theatre

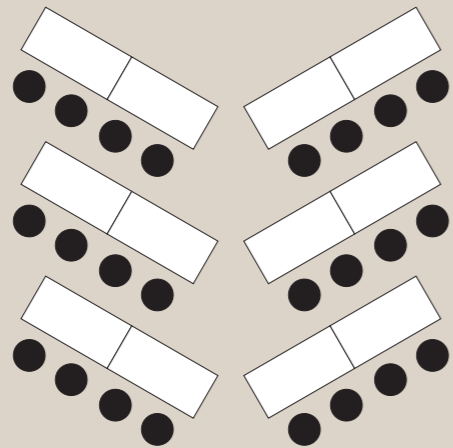

Classroom

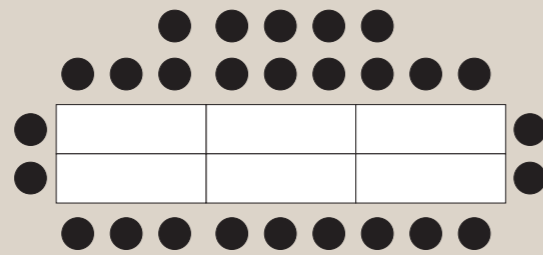

Boardroom

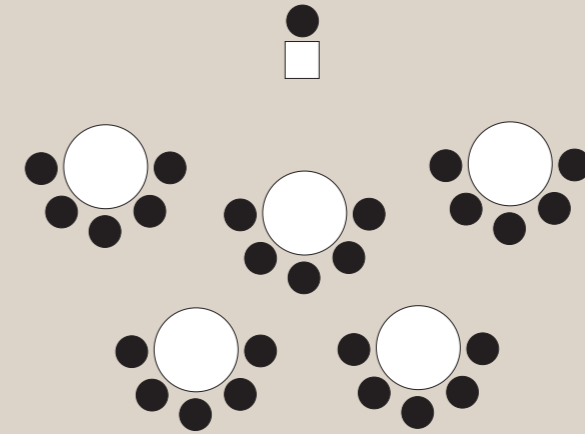

Crescent

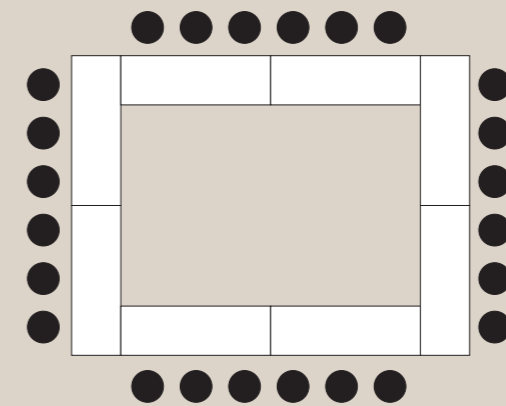

Hollow

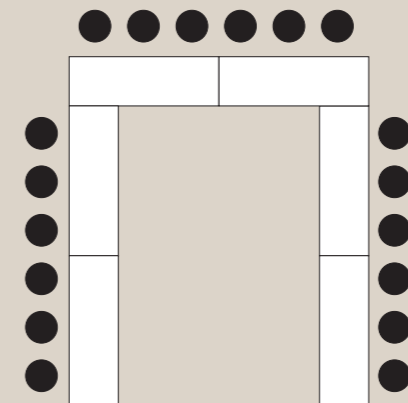

U-shape

# Hollow

- Good for group discussions and brainstorming as it can accommodate the agendas of multiple speakers.
- Great for large meetings when interaction is required among participants without the presence of a leader or presenter,
- Provides good workspace, communication, and view of each attendees.
- This configuration requires a large room.
- Dynamic movement needed to change from one configuration to another.



Swift  
 Worktop in MFC Black.  
 Base in chrome and black finish.  
 Como Rib chairs in white leather.

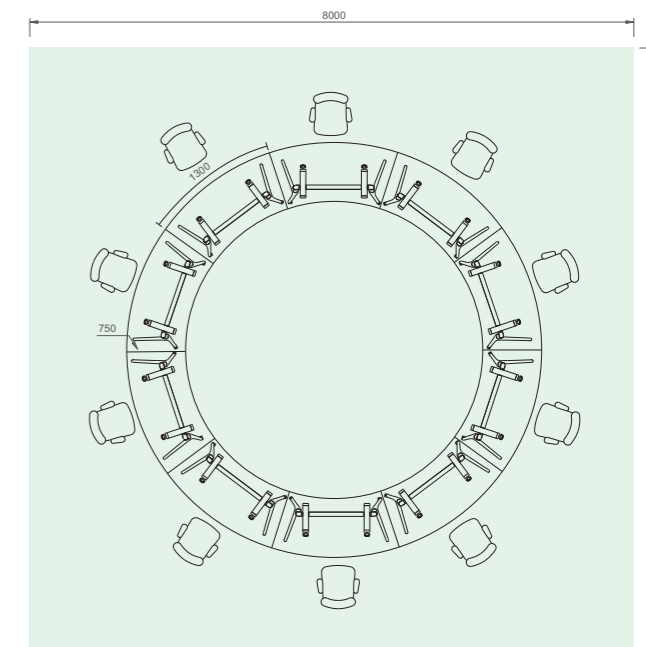
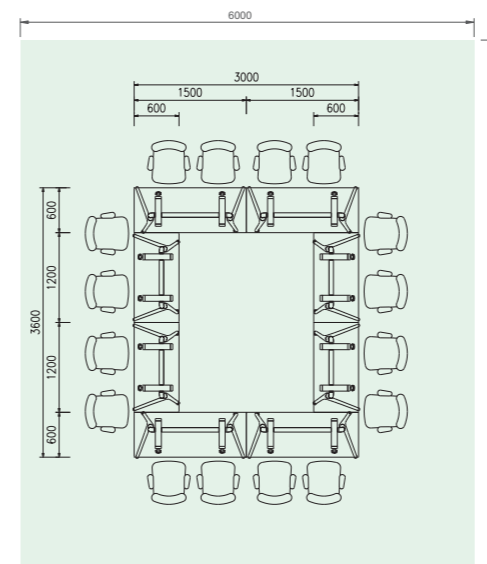

Swift  
 Worktop in MFC Ahorn Natur.  
 Base in white sand finish.  
 Presa chairs in black mesh and fabric seat.

# Crescent

- Best for educational / training session that has many small groups.
- Allows visibility to focal point / trainer.
- Promotes group interaction.

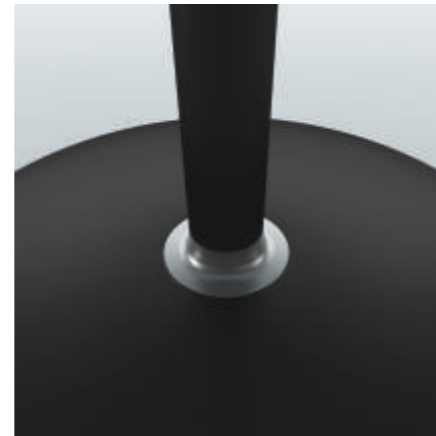
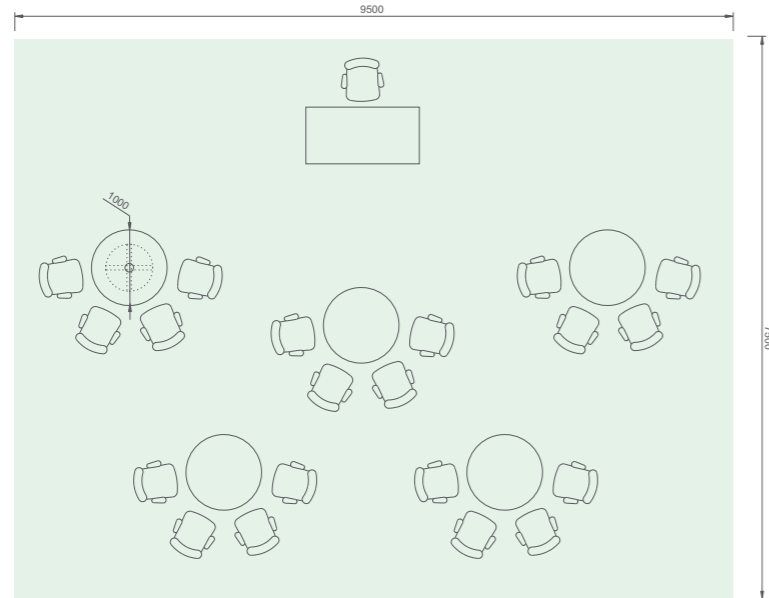

Fadz round base  
Worktop in MFC White.  
Base in silver matte finish.  
Kleiber chairs in full fabric.

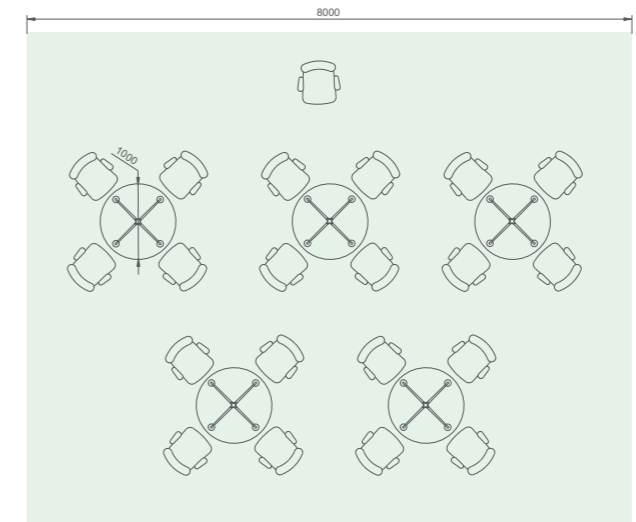

Sunflower  
Worktop in MFC Aborn Natur  
Base in champagne finish.  
Merlin chairs in full fabric.

# Theater / Classroom

- Flexible and efficient.
- Maximizes the seating capacity.
- Best used for short sessions.
- Rows can be circular, semi-circular, straight or angled towards the focal point.
- Good for large groups.
- Promotes minimal interaction.

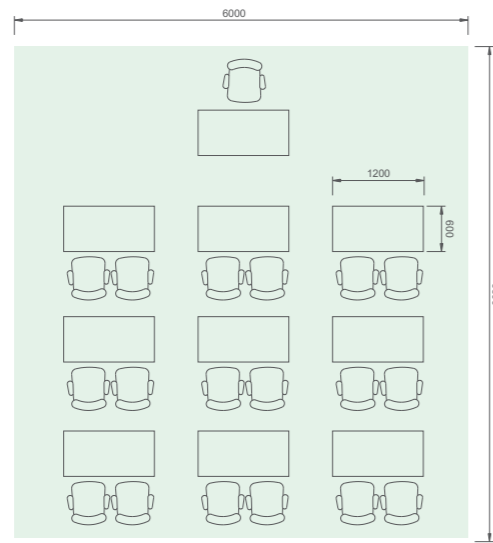

Swift  
Worktop in MFC White.  
Base in chrome and black finish.  
Kleiber chairs in full fabric.



Kleiber with tablet  
Seat in cushion fabric.  
Base in silver matte finish.  
Kleiber chairs in fabric cushion seat.

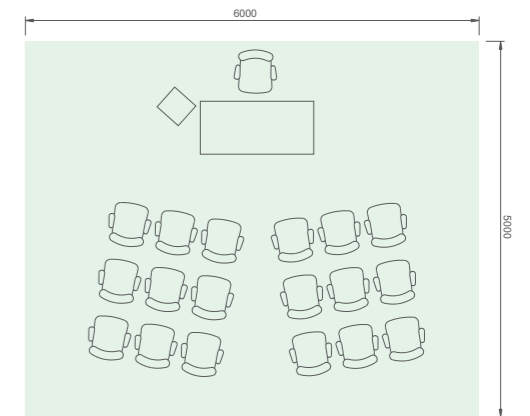

# Conference/Boardroom

- Encourages a communicative and professional setting with ample room for teleconferencing and AV presentation.
- Suitable for formal meetings.

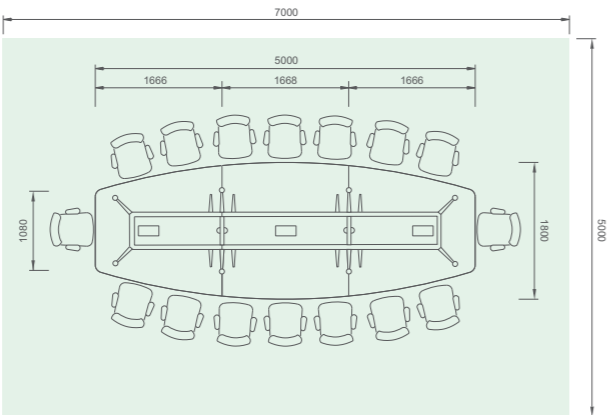

Como Glass  
 Worktop in transparent glass and Formica 5483UN Mocca Firwood.  
 Base in chrome finish.  
 Como Talk chairs in white mesh.

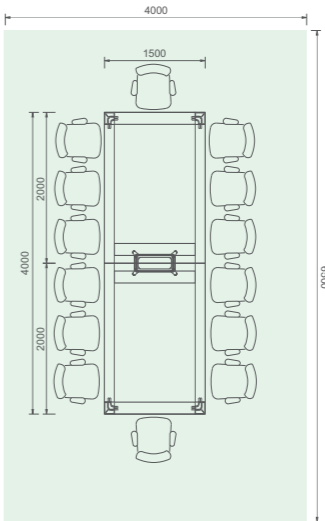

O series  
 Worktop in HPL 9006UN Feline Chocolate.  
 Base in silver matte finish.  
 Como Air chairs in black mesh.

## U-Shape

- Ideal for presentation. Participants are able to see each other, thus encouraging lively discussions and exchange of ideas.
- Not recommended for large groups as the length of the U-shape may get too long and hinders interaction.

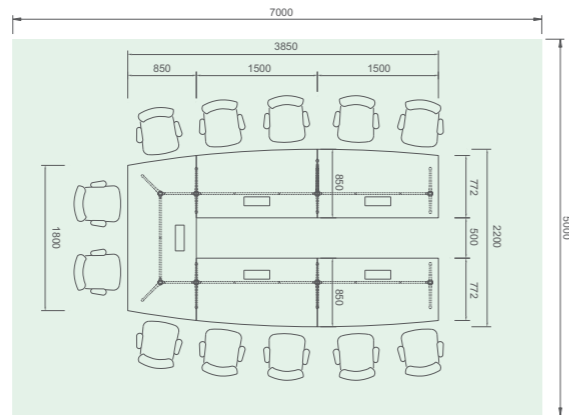

*Fadz*  
 Worktop in HPL 0909UN Black.  
 Base in chrome and black finish.  
 Como Talk chairs in black mesh.

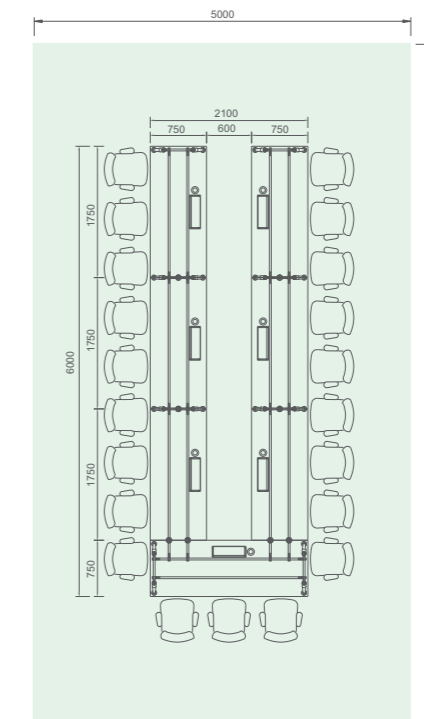

*Artiv*  
 Worktop in HPL 6930NT Natural Cane.  
 Base in black sand finish.  
 Como Talk chairs in black mesh.