

Como Office



All pictures are for illustration purposes. Colours, product dimension, specification as well as designs are subject to change without prior notice. Colours shown here may differ from the actual product.

Rev 2.0 July 2016



bristol MALAYSIA
Bristol Technologies Sdn Bhd
Lot 5178 Balakong Jaya Light Industri
43300 Seri Kembangan, Selangor, Malaysia.
Tel: +603 8962 3233
Fax: +603 8962 6322
Email : export@bristol.com.my
Web: www.bristol.com.my
www.facebook.com/bristolfurniture

We simply could not take our eyes off the sleek, scintillating form.
We reach out to touch it, to run our hands against its taut,
resilient yet supple surface and cannot keep our hands away.
We throw ourselves onto it, only to be cradled perfectly, our every anatomy
caressed and comforted. We wonder how perfect a chair can be and
without doubt and with absolute ease, we concurred.

COMO comes very close to perfection





COMO RIB



Our eyes have a natural tendency to seek beauty. COMO RIB has an alluring beauty that transcends time and place, perhaps even rational thinking. Far beyond fleeting first impressions, visual recollections of its compelling organic lines and contours linger on ceaselessly, never diminishing with time, to ultimately satiate our innate need for aesthetic pleasures.

Perfectly parallel horizontal lines are heat pressed on soft aniline leather and a base of reinforced membrane with a polyurethane foam core creating unique rib contours that ripple majestically along the entire chair.



In the end, we shall sit on resilient columns of air.
Marcel Breuer

Not quite, but not far fetched either. AIR™, a high performance woven mesh exclusive to COMO AIR™, is virtually 50% air. Where air is woven into structure, transparency, lightness and mimicry of biological breathing membranes cohere to deliver an ethereal experience significantly greater than the sum of its parts.



COMO AIR



Once again, less is more. COMO AIR seduces with maximum performance using minimum material. COMO AIR flirts in an almost transparent manner with every body contour and movement yet remarkably maintain and retain its original shape, defying time and physics.

Gram for gram, AIR is one of the strongest upholstery materials available. Woven mesh has widespread commercial application from scientific apparatus to sportswear, and more recently for furniture upholstery.





COMO PAD



Dignified and luxurious, COMO PAD suggest upper class sensibilities combined with modern day pragmatism. The high degree of craftsmanship required to sew and upholster the pads recalls the respected bespoke tradition of tailoring and highlights just how remarkably COMO interprets age old tradition to benefit the modernist form.

Plump and inviting, the pads are hand sewn with French stitching on carefully selected aniline leather of the softest nature, with each pad judiciously filled by hand with polyester encapsulated foam to ensure only pads with perfect crowns are made.

Sophistication lives here. Slim, supple yet relaxed, COMO LINE captivates with charm and grace of a confident dancer moving in line with rhythm. Deliberately simple yet bold moves, perfectly executed corner tucks and a soft yet firm landing ensures a performance that comes close to perfection.

COMO LINE takes inspiration from LINEA chair, introduced by Bristol since 1993 and a highly popular chair till today, a chair which features the unique upholstery technique of 'not too tailored' quilting on soft aniline leather with flat piped border to produce a relaxed, artistic form.

COMO LINE



COMO BOSS



Como Boss is the latest addition to the COMO chair series which features a much more refined shape and better comfort level.

It has been improvised to fit your sedentary lifestyle better. Covered with luxurious leather, providing optimal comfort while supporting your lumbar and sitting posture perfectly.

Como Boss is reliable in everyday use yet adding exquisite taste to enhance the overall atmosphere of your office.



COMO TALK



Como Talk is an enhanced version of our Como Office series chairs.

It is a chair which comes with the brilliant Auto - Return Swivel Base also known as the 'Memory Return Swivel Chair'. It will always swing back to its original position which saves you the time to rearrange the seat after use. Therefore, it is ideal for meeting or discussions.

Last but not least, the slender five-star base in die-cast aluminium with studs provides stability in any position.



COMO AIR, RIB, PAD, LINE, BOSS with Talk base



Symbiosis has never been this perfect.

By infusing the five-star base from Como Talk, it breathes in fresh aesthetics to the existing Como Office series. The end result is a simple, classic looking, minimalistic chair which transcends time.

FEATURES

Arm



• Without armrest



• With armrest



• Armrest with armpad
• Only for Como Boss



• Armrest with armcover

Mechanism and Base



• Mantis base with nylon castors
• Tilting mechanism



• Talk base with nylon castors
• Tilting mechanism



• Talk base with studs
• Auto-return mechanism
• Only for Como Talk



COMO AIR



COMO AIR (with Talk base)



COMO TALK (AIR)



COMO RIB



COMO RIB (with Talk base)



COMO TALK (RIB)



COMO PAD



COMO PAD (with Talk base)



COMO TALK (PAD)



COMO LINE



COMO LINE (with Talk base)



COMO TALK (LINE)



COMO BOSS



COMO BOSS (with Talk base)



COMO TALK (BOSS)



COMO Office Statement of line

General Specification

Aluminium frame, arms and base in chromed finish.
Torsion bar mechanism in black epoxy powder coated.
Tilting mechanism with upright position locking control.
Chromed gaslift.
Chromed Mantis base with castors.
Full compliance to ANSI/BIFMA X5.1-1993.

COMO AIR

0.55mm thick nylon mono filament mesh on the backrest
and with tarpaulin backing for the seat.

COMO PAD

Padded semi-aniline leather cushions on seat and back
stitched on tensioned leather backing.

COMO RIB

Repetitive heat pressed line pattern on tensioned
semi-aniline leather seat/back.

COMO LINE

12.5mm thick padded semi-aniline leather cushions on
seat and back, stitched on tensioned leather backing.

COMO BOSS

Padded semi-aniline leather cushions on seat and back
stitched on tensioned leather backing.

COMO TALK

Aluminium frame, arms and base in chromed finish.
Auto-return mechanism in chromed finish.
Fixed seat height without tilting mechanism.
Chromed Talk base with studs.
Full compliance to ANSI/BIFMA X5.1-1993.

COMO AIR, RIB, PAD, LINE, BOSS with Talk base

Aluminium frame, arms and base in chromed finish.
Torsion bar mechanism in black epoxy powder coated.
Tilting mechanism with upright position locking control.
Chromed gaslift with height adjustment of 110mm.
Chromed Talk base with castors.
Full compliance to ANSI/BIFMA X5.1-1993.

COMO AIR, RIB, LINE

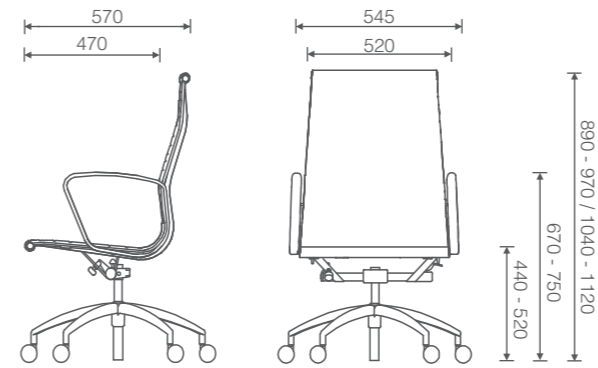

COMO AIR, RIB, LINE with Talk base

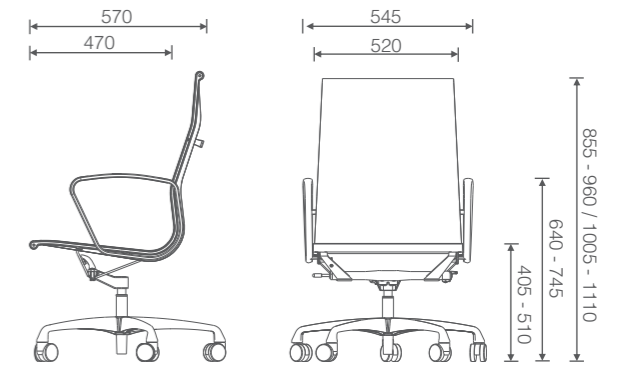

COMO PAD

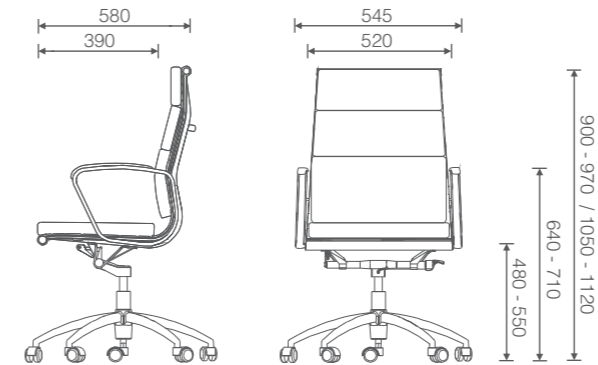

COMO PAD with Talk base

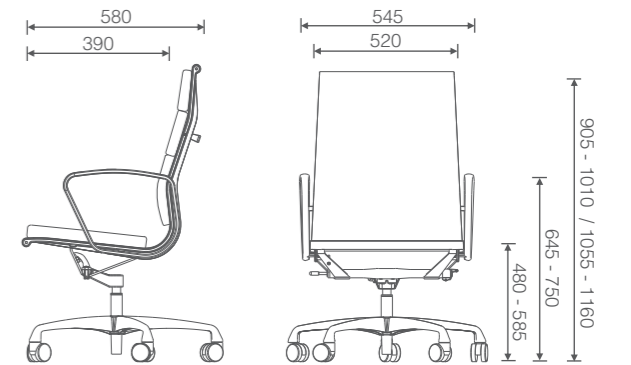

COMO BOSS

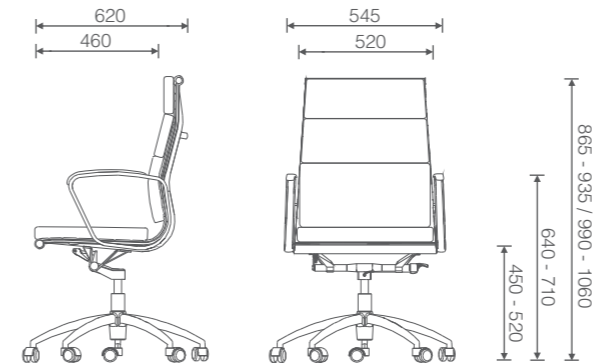

COMO BOSS with Talk base

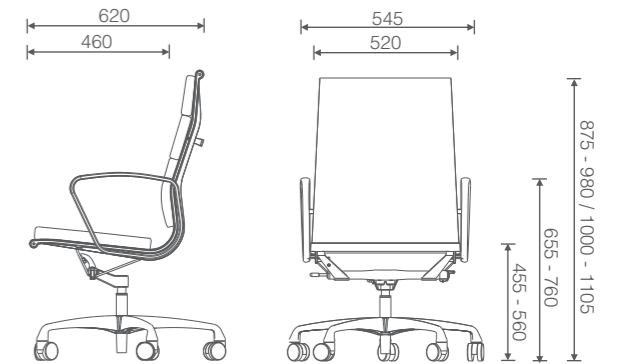

COMO TALK

